



FULL CONTROL BOARD MANUAL

<https://www.bft-automation.com/qrcodemanual/D814461>

ARES BT B 1000 ARES BT B 1500



D814461_0ADA0_04_28-01-26

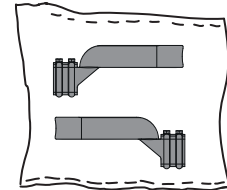
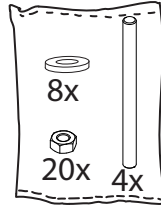
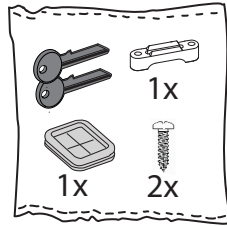
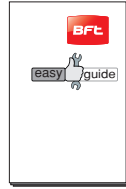
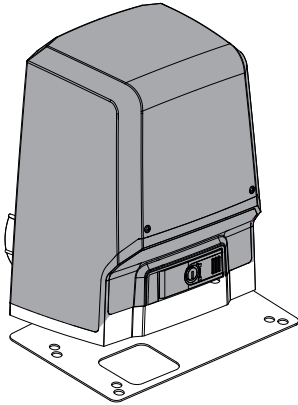

IT	LINGUA ORIGINALE	PL	WERSJA TŁUMACZONA
EN	TRANSLATED VERSION	RU	ПЕРЕВОДНАЯ ВЕРСИЯ
FR	VERSION TRADUITE	CS	PŘEKLOŽENÁ VERZE
DE	ÜBERSETZTE VERSION	TR	ÇEVİRİLEN VERSİYON
ES	VERSIÓN TRADUCIDA	HR	PREVEDENA VERZIJA.
NL	VERTAALDE VERSIE	RO	VERSIUNE TRADUS
PT	VERSÃO TRADUZIDA		
EL	ΜΕΤΑΦΡΑΣΜΕΝΗ ΕΚΔΟΣΗ		النسخة المترجمة

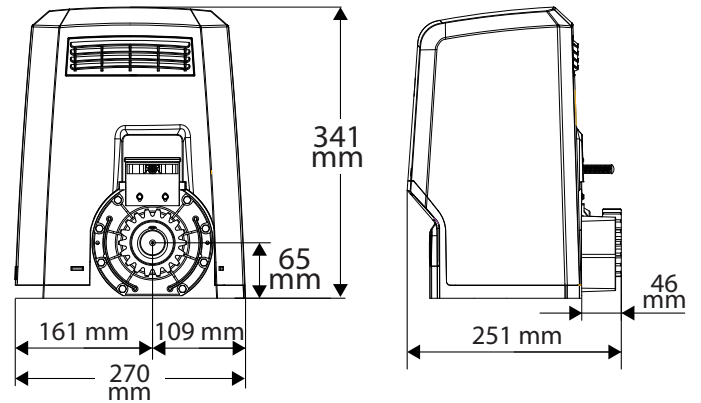
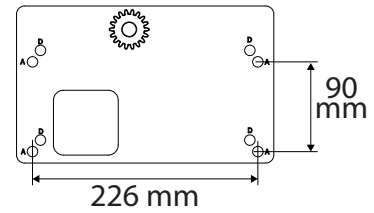

IT	Verifica la tua composizione nell'etichetta imballo.
EN	Check your composition on the packaging label
FR	Vérifiez votre composition sur l'étiquette d'emballage.
ES	Controla la composición de tu kit en la etiqueta del embalaje
DE	Überprüfen Sie Ihre Zusammenstellung auf dem Verpackungsetikett.
NL	Controleer uw samenstelling op het verpakingslabel.
PT	Verifique a composição no rótulo da embalagem
EL	Ελέγξτε τη σύνθεση του κιτ στην ετικέτα της συσκευασίας
PL	Prosimy sprawdzić zawartość zestawu na etykiety opakowania
RU	Проверьте комплектацию на этикетке упаковки.
CS	Zkontrolujte složení sady na štítku obalu.
TR	Ambalaj etiketindeki bileşiminizi kontrol edin
HR	Na etiketi provjerite sastav svojeg paketa
RO	Verificați-vă compoziția de pe eticheta ambalajului
	تحقق من التركيبة إلى ملصق العبوة

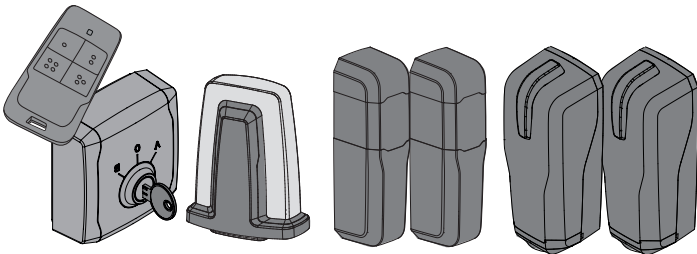

Example

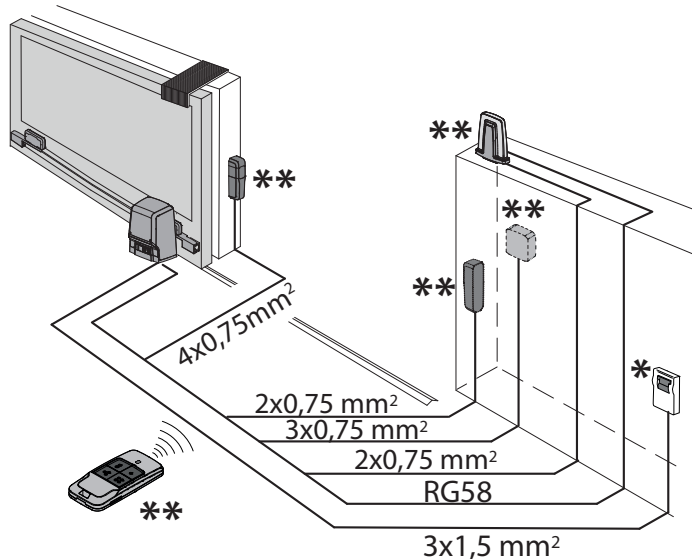

	ARES BT B 1000	ARES BT B 1500
--	----------------	----------------

	220-230 V 50/60 Hz	
P stand-by	0,43 W	
Pmax	130 W	160 W
	433,92 MHz	
IP	24	
	-20°C / +55°C	
Consecutive cycles	20	15
	<70 dBA	
Speed max	12m min	
	500 kg-20 Nm	750 kg-30 Nm
	1000 kg-20 Nm	1500 kg-30 Nm



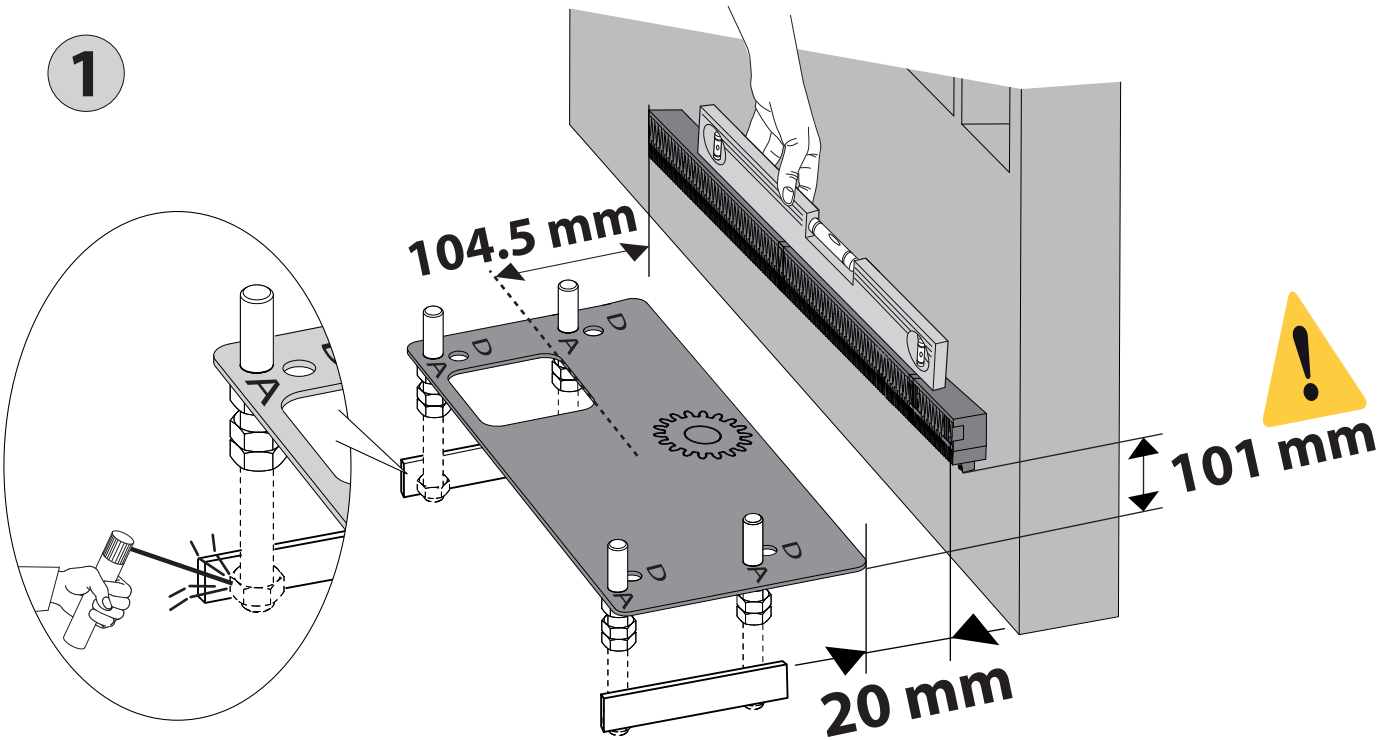
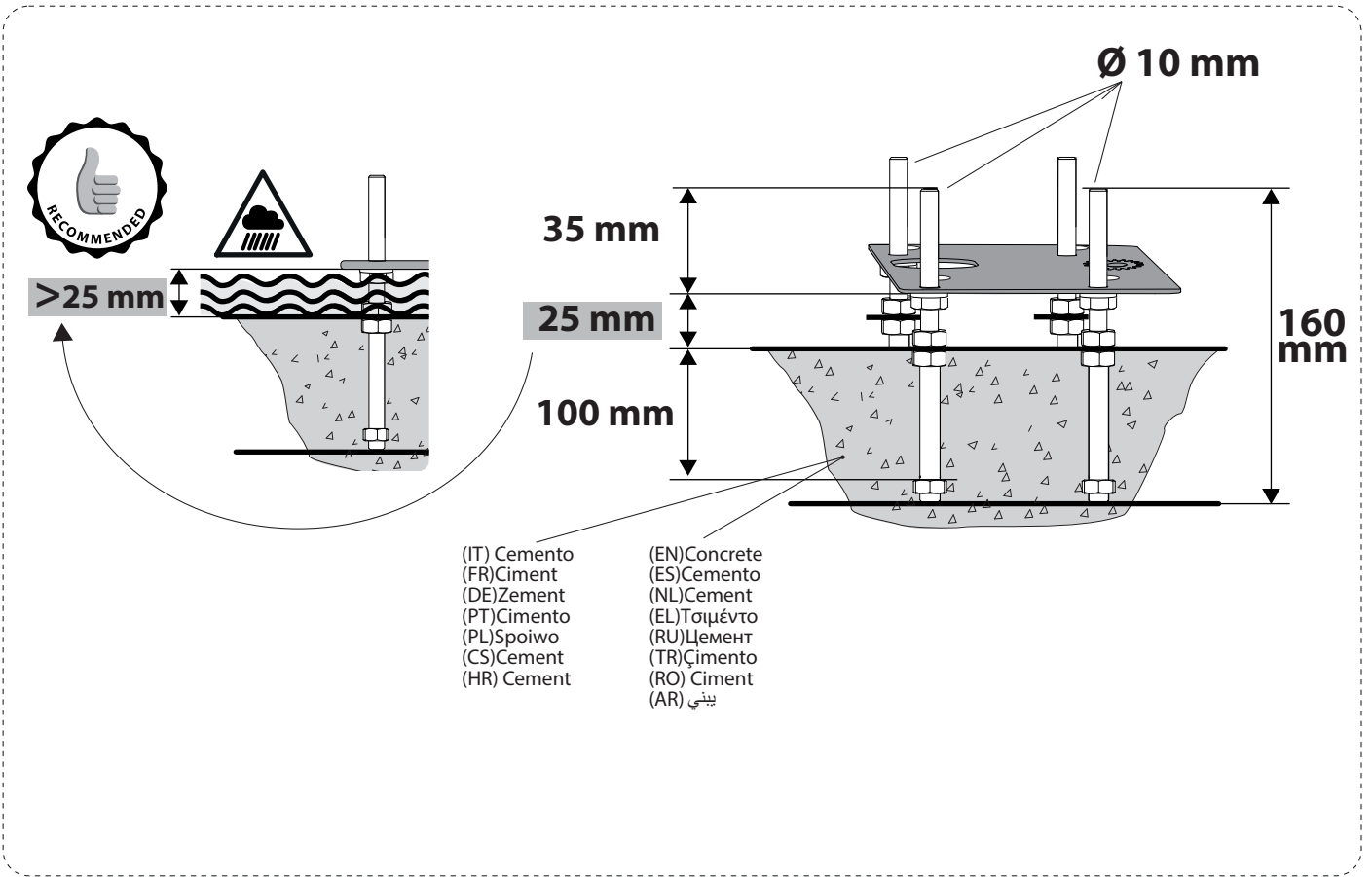

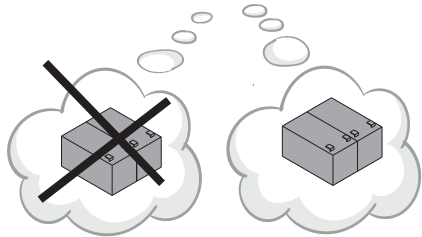
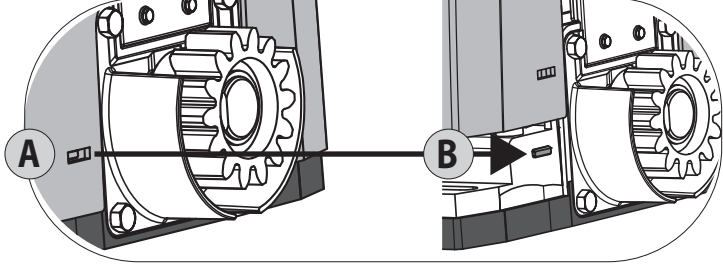
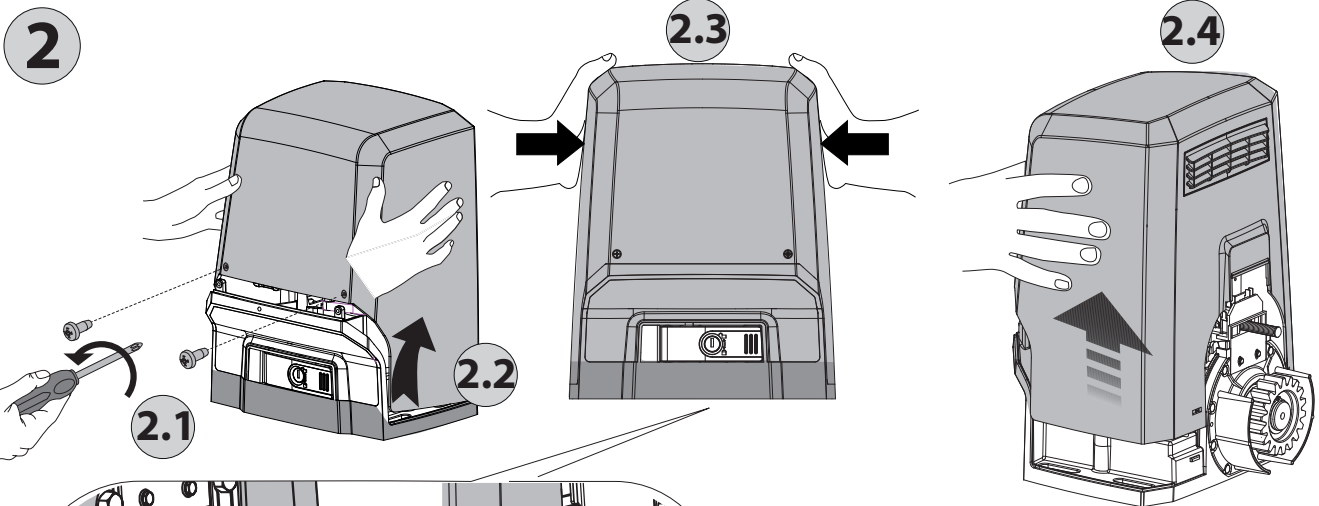

SL BAT2

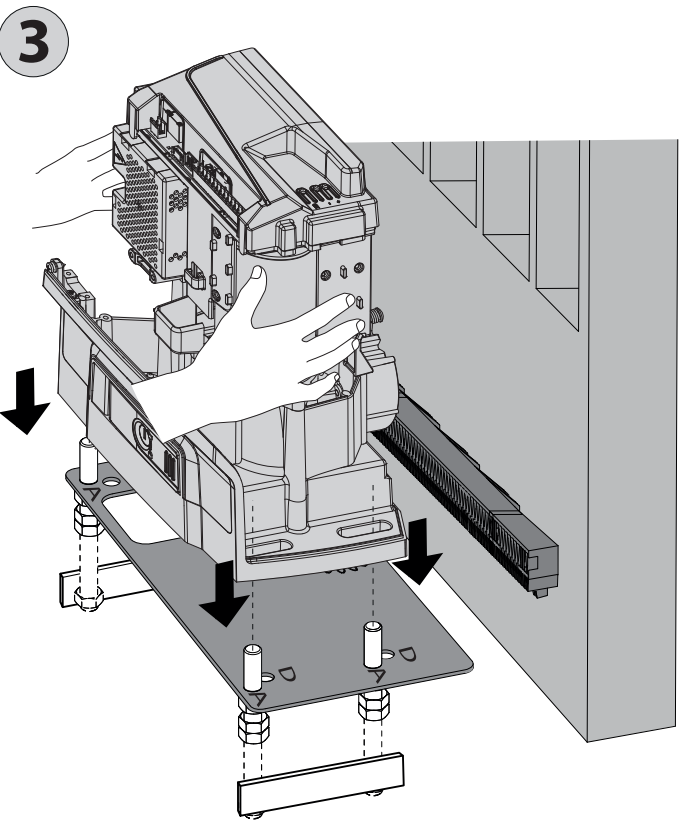
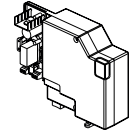

3

3

4

A 

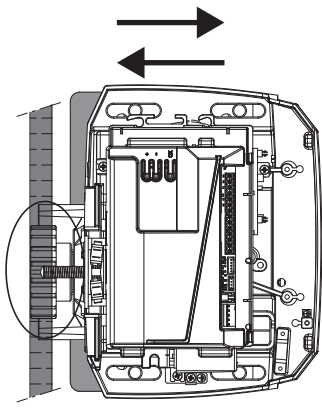

B

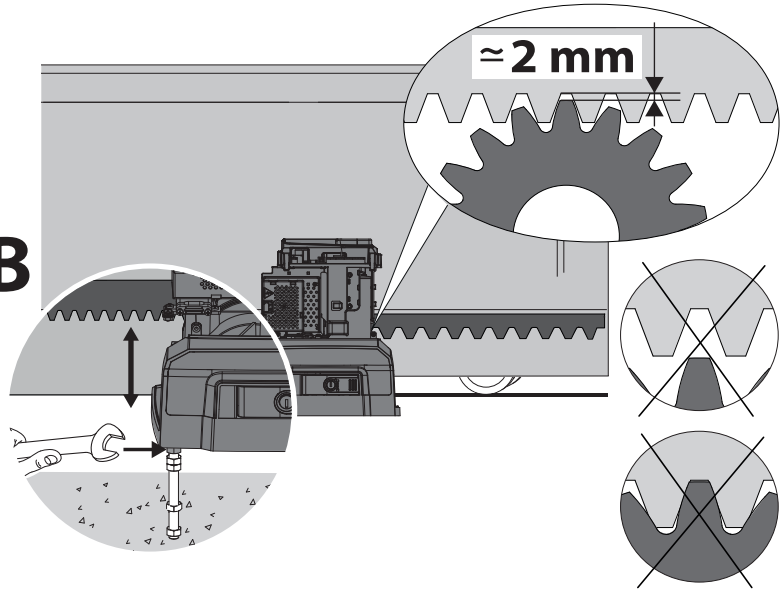

5

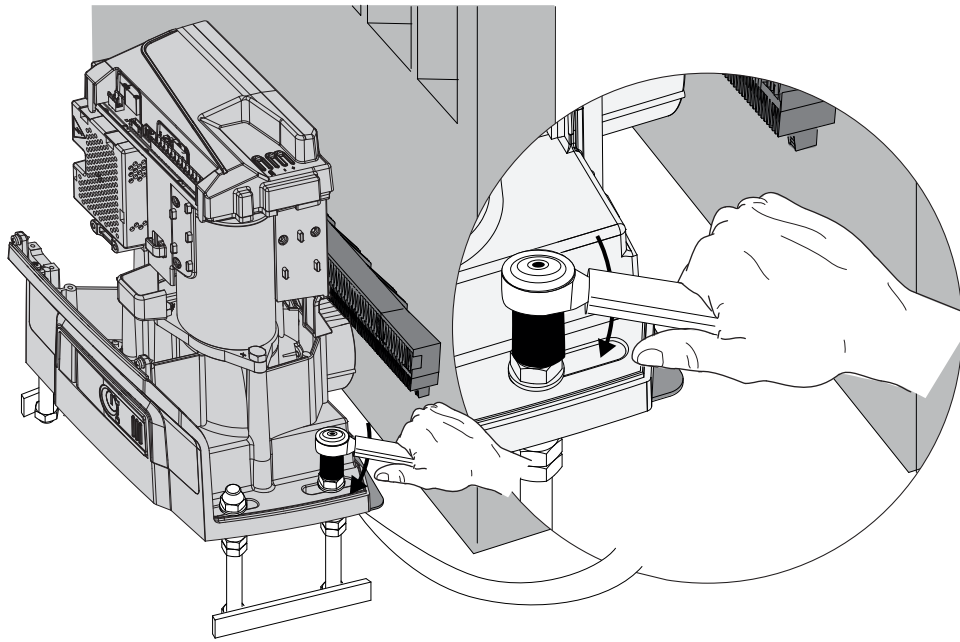

6

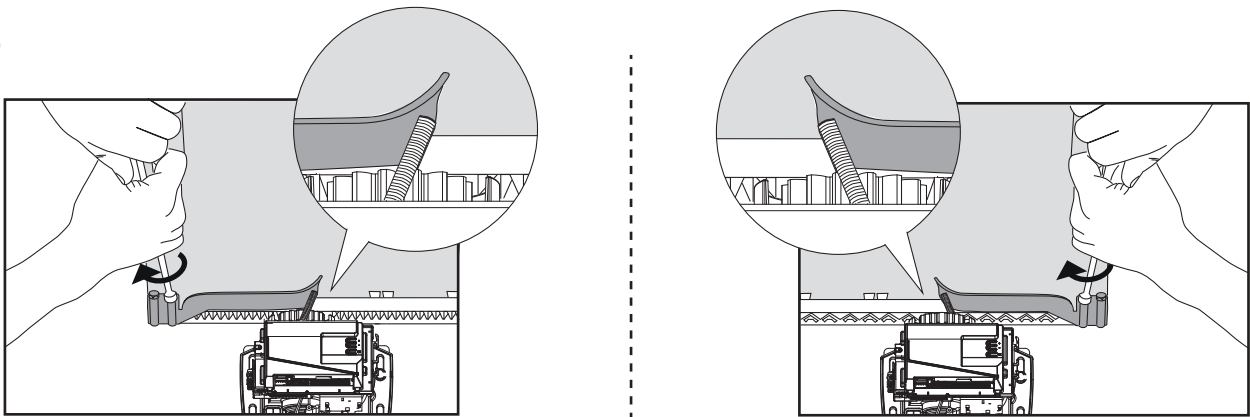

Sinistra
Left
Gauche
Links
Izquierda
Links
Esquerda
Αριστερά
Lewa
Levo
Vlevo
Sol
Lijevo
Stânga
اليسار

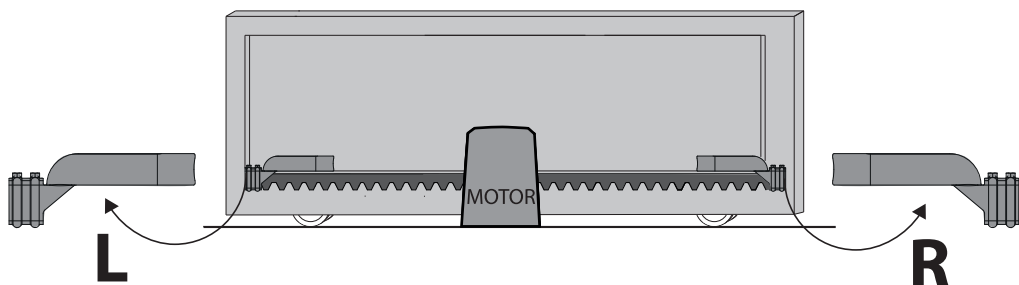

Destra
Right
Droite
Rechts
Derecha
Rechts
Direita
Δεξιά
Pravo
Pravo
Vpravo
Såg
Desno
Dreapta
اليمين

7

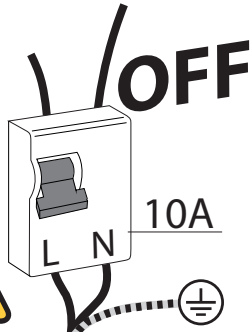
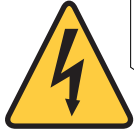

Ø 20
3x1,5 mm²
R02V-H05VVF

220-230V
50/60 Hz

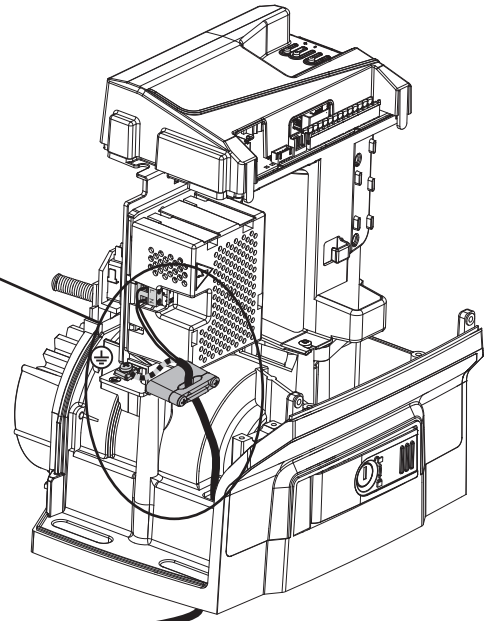
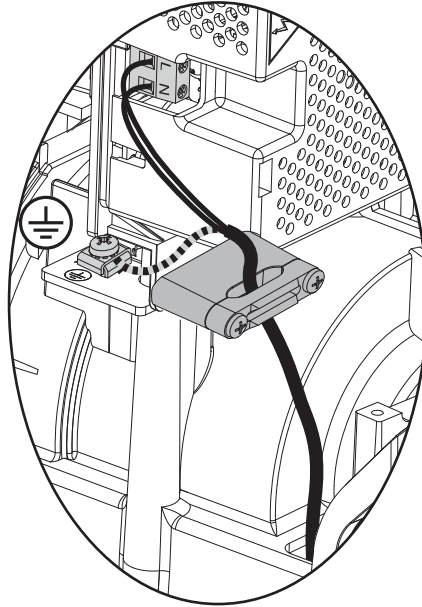

IT	APERTURA COPERTURA SCHEDA	NL	KAARTAFDEKKING OPENEN	CS	OTEVÍRÁNÍ KRYTU KARTY
EN	OPENING BOARD COVER	PT	ABERTURA COBERTURA PLACA	TR	KART KAPLAMASININ AÇILMASI
FR	OUVERTURE DU COUVERCLE DE LA CARTE	EL	ΑΝΟΙΓΜΑ ΚΑΛΥΜΜΑΤΟΣ ΚΑΡΤΑΣ	HR	OTVARANJE POKLOCA PLOČE
DE	ÖFFNUNG KARTENABDECKUNG	PL	OTWIERANIE OSŁONY KARTY	RO	DESCHIDEREA CAPACULUI DULAPULUI
ES	APERTURA CUBIERTA TARJETA	RU	ОТКРЫТИЕ КРЫШКИ ПЛАТЫ	AR	جارٍ فتح غطاء اللوحة

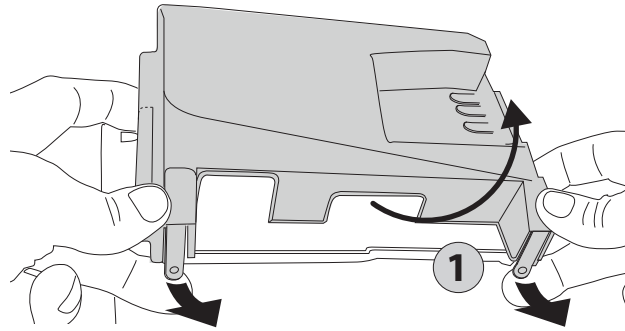

IT	CHIUSURA COPERTURA SCHEDA	NL	KAARTAFDEKKING SLUITEN	CS	ZAVÍRÁNÍ KRYTU KARTY
EN	CLOSING BOARD COVER	PT	FECHE COBERTURA PLACA	TR	KART KAPLAMASININ KAPANMASI
FR	FERMETURE DU COUVERCLE DE LA CARTE	EL	ΑΝΟΙΓΜΑ ΚΑΛΥΜΜΑΤΟΣ ΚΑΡΤΑΣ	HR	ZATVARANJE POKLOCA PLOČE
DE	SCHLIESSUNG KARTENABDECKUNG	PL	ZAMYKANIE OSŁONY KARTY	RO	ÎNCHIDEREA CAPACULUI DULAPULUI
ES	CIERRE CUBIERTA TARJETA	RU	ЗАКРЫТИЕ КРЫШКИ ПЛАТЫ	AR	جارٍ إغلاق غطاء اللوحة

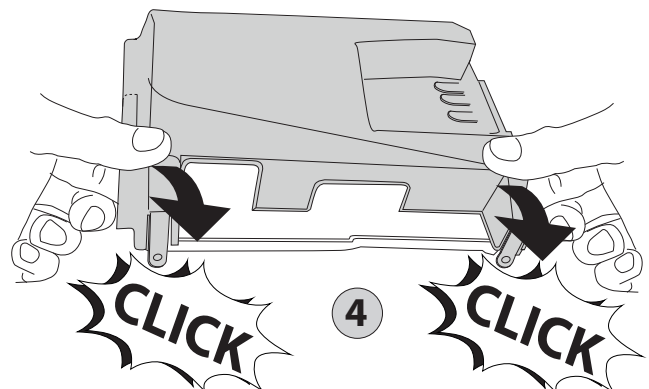
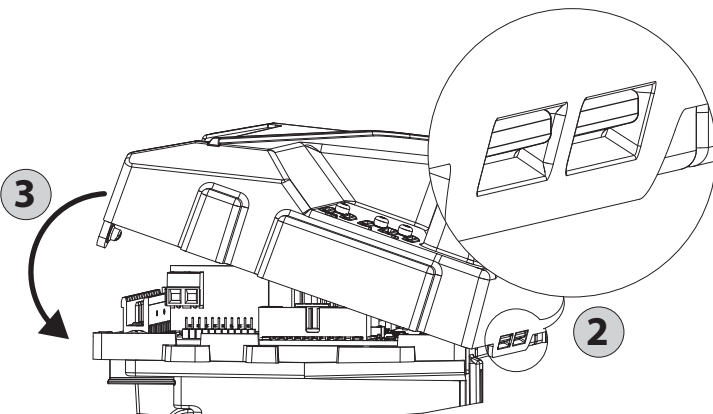

MECHANICAL LIMIT SWITCHES

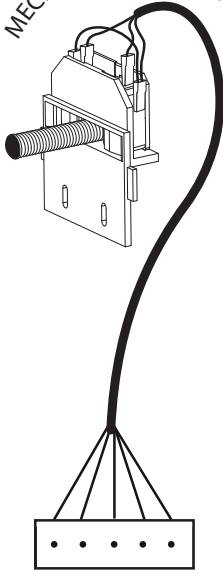
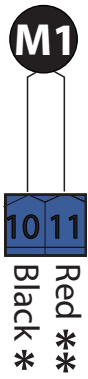

AUX 1 - 24V (MAX 1A)

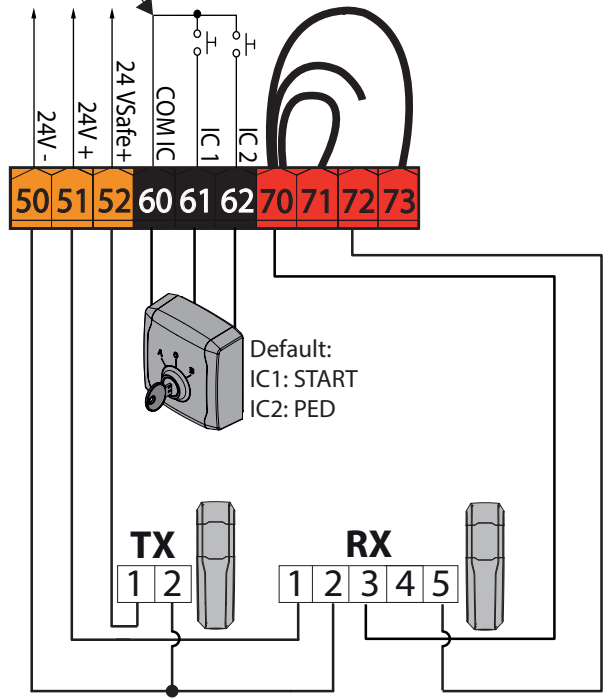
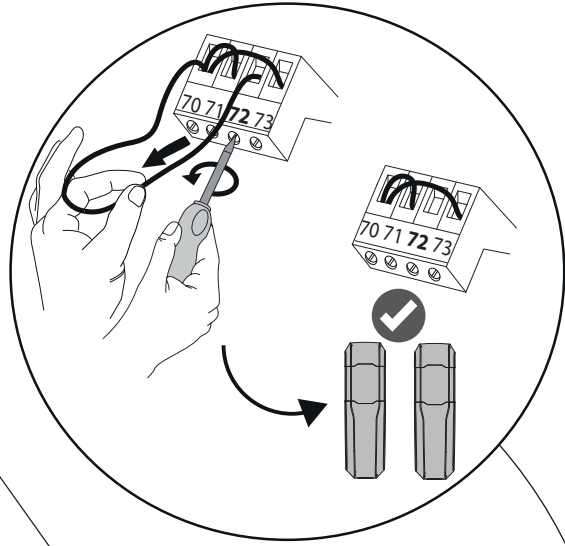
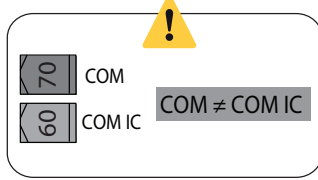
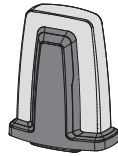
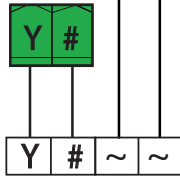
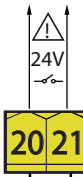

Default:
IC1: START
IC2: PED

	*	**
IT	Nero	Rosso
EN	Black	Red
FR	Noir	Rouge
DE	Schwarz	Rot
ES	Negro	Rojo
NL	Zwart	Rood
PT	Preto	Vermelho
EL	ΜΑΥΡΟ	κόκκινο
PL	Czarny	czzerwony
RU	ЧЕРНЫЙ	красный
CS	ČERNÝ	červený
TR	Siyah	kırmızı
HR	Crno	Crvena
RO	Negru	roșu
AR	أسود	أحمر

9

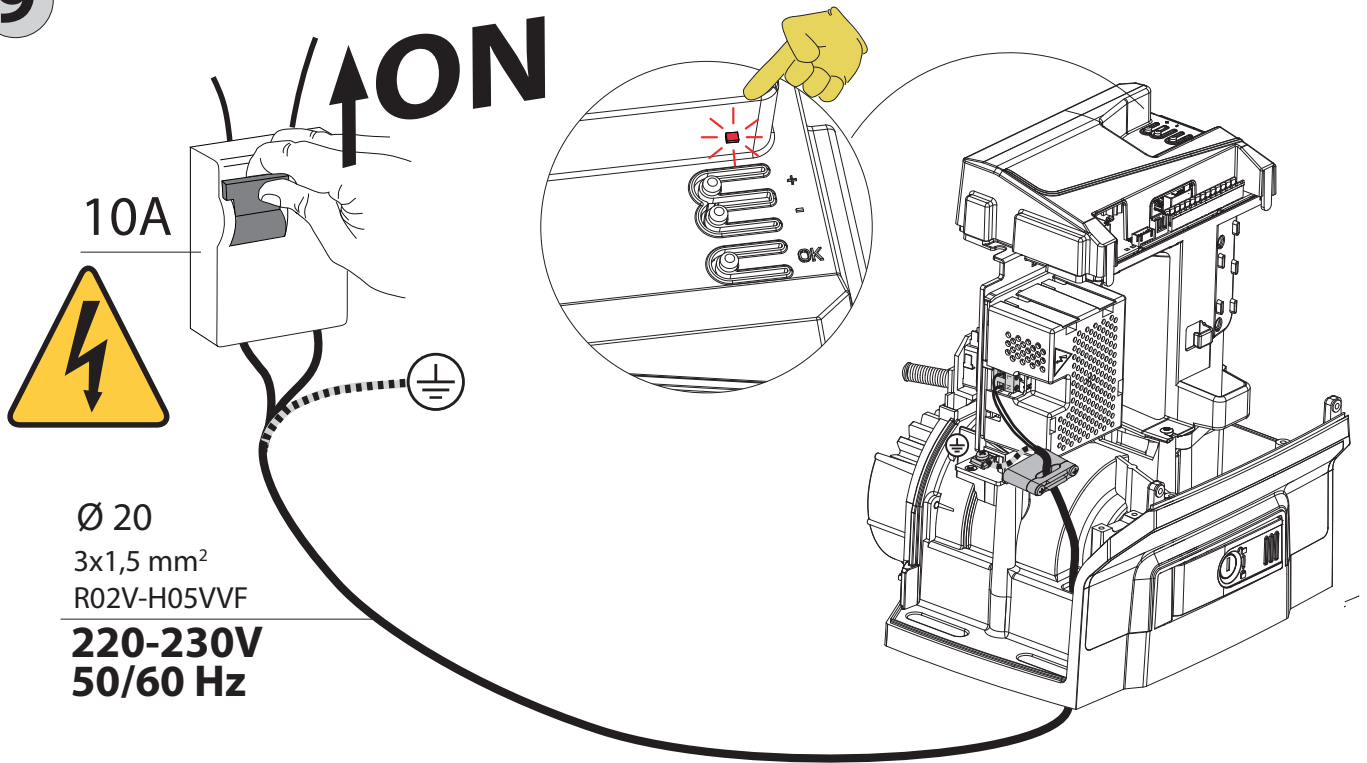

LEGENDA - LEGENDE - LEGEND - LEYENDA - ΥΠΟΜΝΗΜΑ - УСЛОВНЫЕ ОБОЗНАЧЕНИЯ - ANLAMLAR - أسطورة



RADIO

Diagnostica radio
Radio diagnostics
Diagnostic radio
Diagnose der Funksteuerung
Diagnóstico radio
Radiodiagnose
Diagnóstico rádio
Διάγνωση ασυρμάτου
Diagnostyka radiowa
Радиодиагностика
Rádiová diagnostika
Radyo tanilama
Radiodijagnostika
Diagnosticare radio
صنات بموجات الراديو



+



Aggiungi start
Add Start Key
Ajouter Touche Start
Hinzufügen Taste Start
Añadir Tecla start
Toets start toevoegen
Adiciona Tecla start
Προσθήκη Μπουτόν start
Dodaj Przycisk Start
Добавить клавишу Start (Пуск)
Přidej tlačítko start
Start tuşu ekle
Dodaj tipku Start
Adăugarea tastei Start
إضافة مفتاح بدء



SET

Diagnostica stato scheda
Board status diagnostics
Diagnostic état de la carte
Karten-Status-Diagnose
Diagnóstico estado tarjeta
Diagnose van de status van de printplaat
Diagnóstico estado placa
Διάγνωση κατάστασης πλακέτας
Diagnostyka stanu płytki drukowanej
Диагностика состояния монтажной платы
Diagnostika stavu desky plošných spojů
Devre karti durum tanilama
Dijagnostika stanja ploče
Diagnostizarea stării plăcii
تشخيصات حالة اللوحة

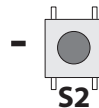

-



Aggiungi secondo canale radio
Add second radio channel
Ajouter Deuxième canal radio
Hinzufügen eines zweiten Funkkanals
Agregar Segundo canal radio
Tweede radiokanaal toevoegen
Adicionar Segundo canal de rádio
Προσθήκη δεύτερου ραδιοδιαύλου
Dodaj drugi kanał radiowy
Добавить Второй радиоканал
Přidat druhý kanál rádia
İkinci radyo kanalı ekle
Dodaj drugi radiokanal
Adăugarea unui al doilea canal radio
إضافة قناة راديو ثانية



ERR

Diagnostica errori
Error diagnostics
Diagnostic erreurs
Fehler-Diagnose
Diagnóstico errores
Störungsdiagnose
Diagnóstico erros
Διάγνωση σφαλμάτων
Diagnostyka błędów
Диагностика ошибок
Diagnostika chyb
Hata tanilama
Dijagnostika grešaka
Diagnosticare erori
تشخيصات الأخطاء



OK

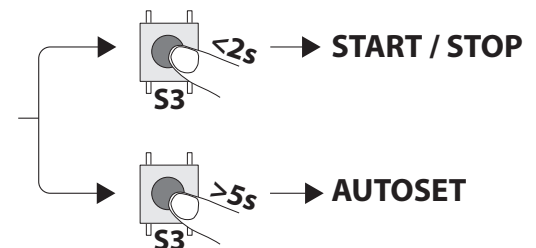
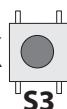

IT APERTURA VERSO DESTRA
 EN OPENING TO THE RIGHT
 FR OUVERTURE VERS LA DROITE
 DE ÖFFNUNG NACH RECHTS
 ES APERTURA HACIA LA DERECHA
 NL OPENING NAAR RECHTS
 PT ABERTURA PARA A DIREITA
 EL ΑΝΟΙΓΜΑ ΠΡΟΣ ΤΑ ΔΕΞΙΑ
 PL OTWARCIE W PRAWO
 RU ОТКРЫВАНИЕ ВПРАВО
 CS OTEVÍRÁNÍ SMĚREM DOPRAVA
 TR SAĞA DOĞRU AÇILMA
 HR OTVARANJE UDESNO
 RO DESCHIDERE CĂTRE DREAPTA

الفتح إلى اليمين AR

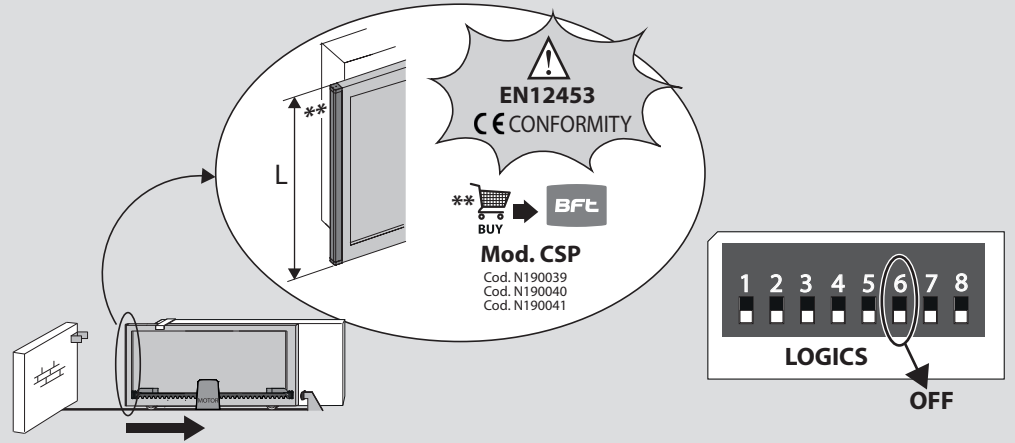

10 AUTOSET

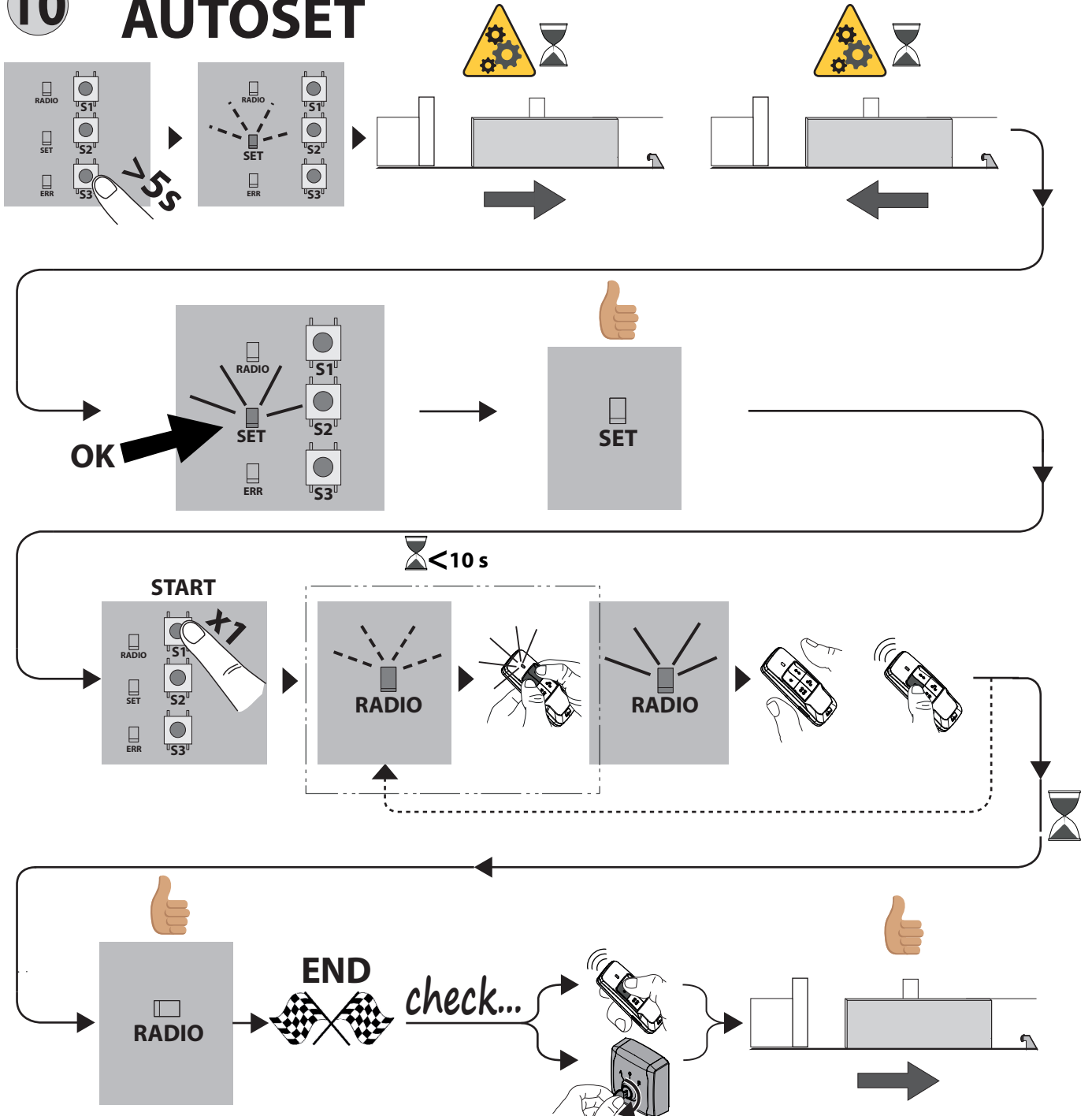

IT APERTURA VERSO SINISTRA
 EN OPENING TO THE LEFT
 FR OUVERTURE VERS LA GAUCHE
 DE ÖFFNUNG NACH LINKS
 ES APERTURA HACIA LA IZQUIERDA
 NL OPENING NAAR LINKS
 PT ABERTURA PARA A ESQUERDA
 EL ΑΝΟΙΓΜΑ ΠΡΟΣ ΤΑ ΑΡΙΣΤΕΡΑ
 PL OTWARCIE W LEWO
 RU ОТКРЫВАНИЕ ВЛЕВО
 CS OTEVÍRÁNÍ SMĚREM DOLEVA
 TR SOLA DOĞRU AÇILMA
 HR OTVARANJE ULIJEVO
 RO DESCHIDERE CĂTRE STÂNGA

الفتح إلى اليسار AR

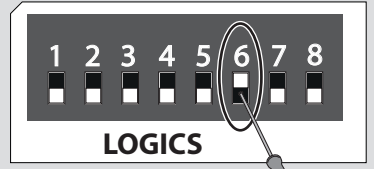
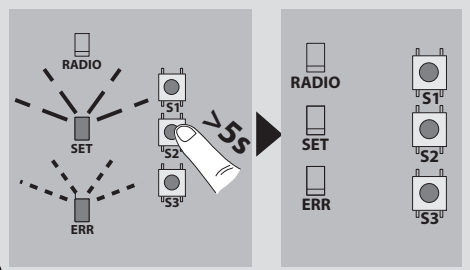
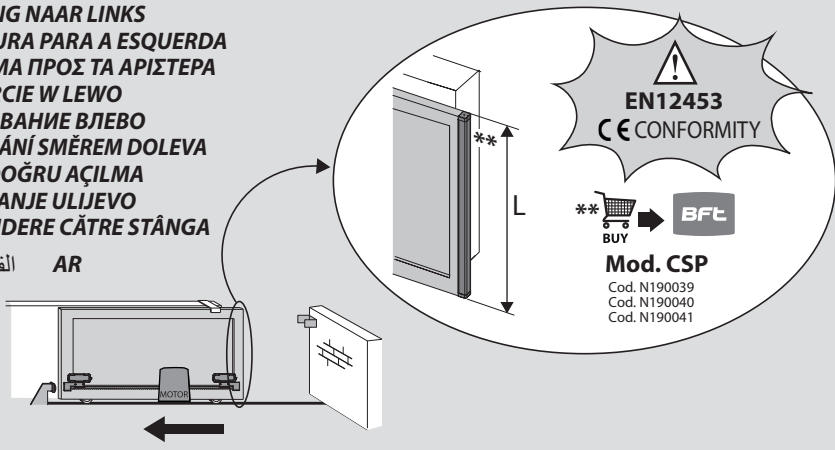

AUTOSET

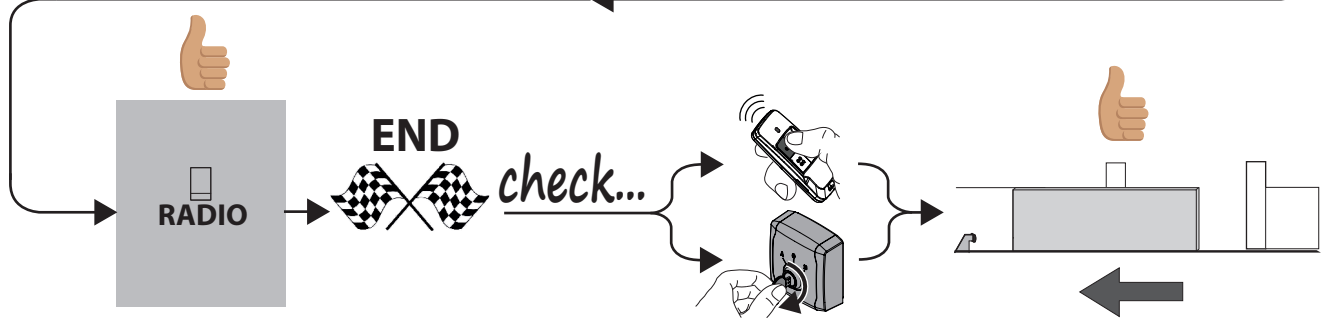
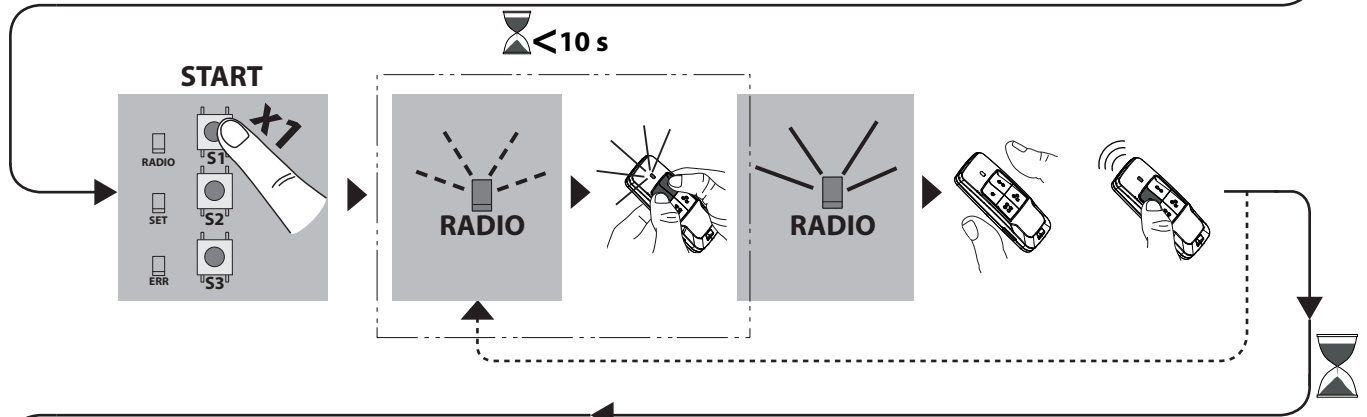
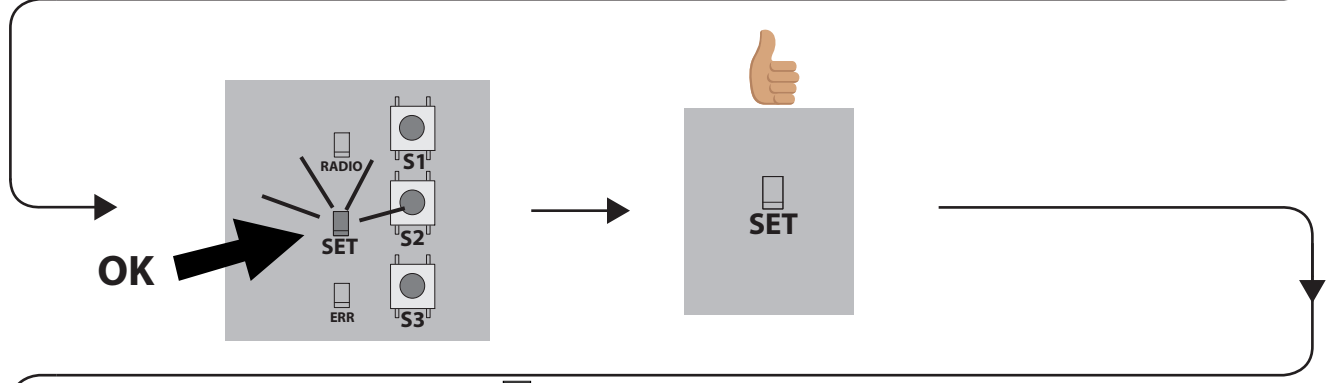
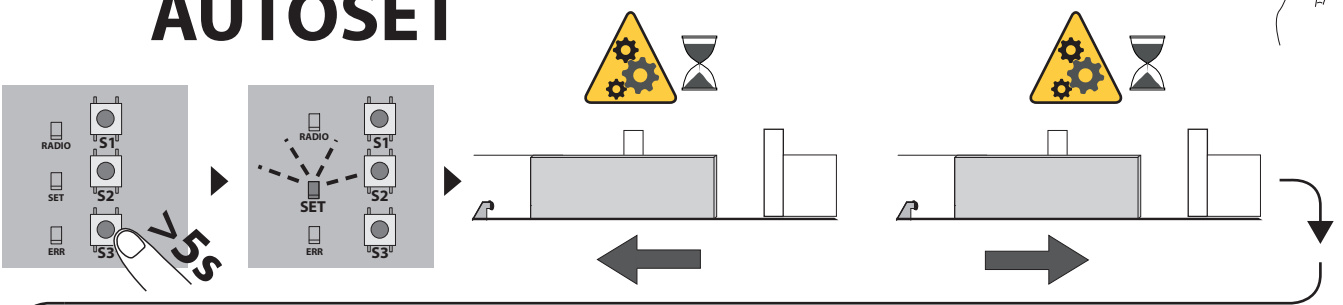



TCA

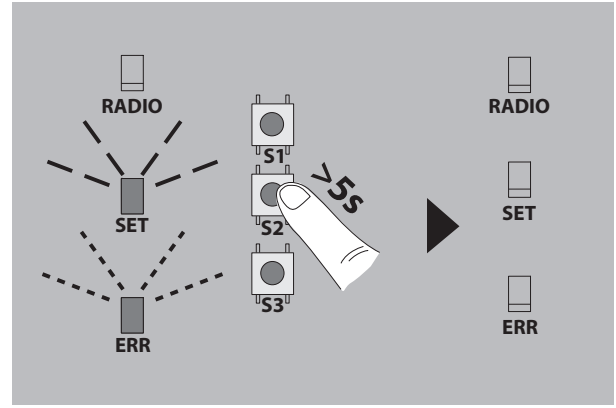
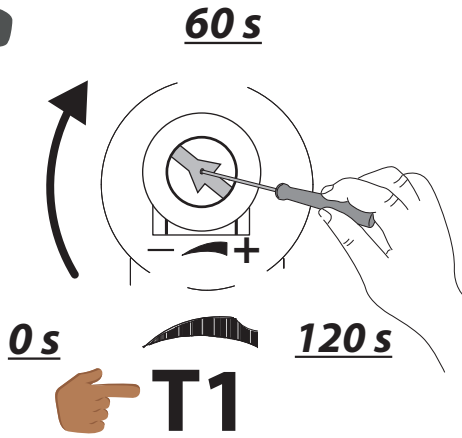

PED

<10 s

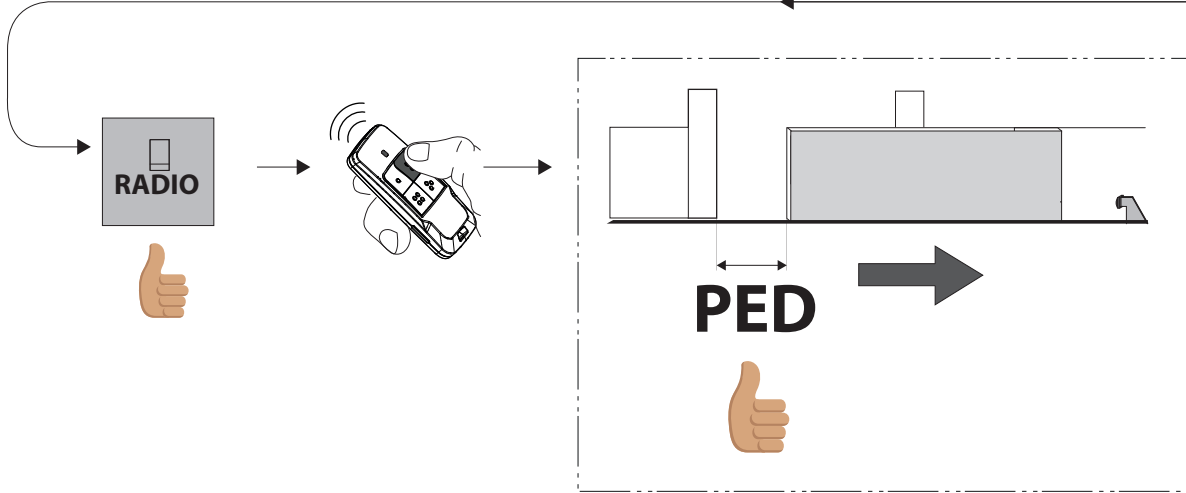
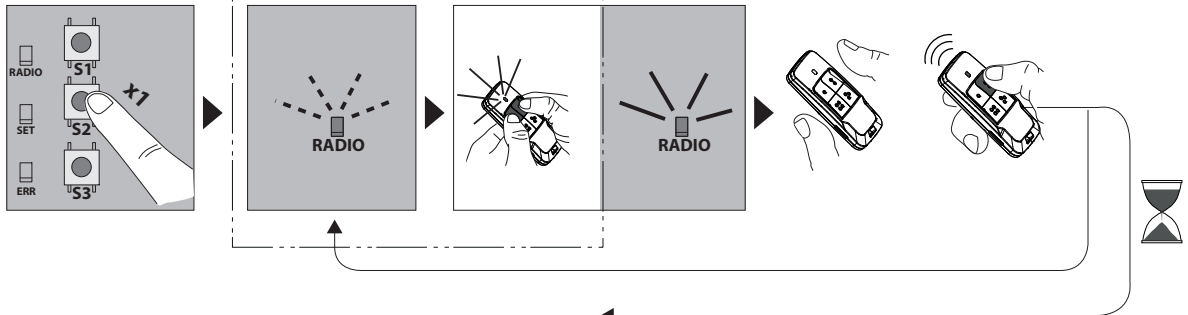

IT	CANCELLAZIONE TRASMETTITORI
EN	TRANSMITTERS CANCELLATION
FR	ANNULATION DES ÉMETTEURS
DE	LÖSCHEN DER SENDER
ES	ELIMINACIÓN TRANSMISORES
NL	WISSEN ZENDERS

PT	CANCELAMENTO DE TRANSMISSORES
EL	ΑΚΥΡΩΣΗ ΠΟΜΠΩΝ
PL	KASOWANIE NADAJNIKÓW
RU	УДАЛЕНИЕ ДАТЧИКОВ
CS	SMAZÁNÍ VYSÍLAČŮ
TR	VERİCİ İPTALİ

HR	OTKAZIVANJE ODAŠILJAČA
RO	ȘTERGEREA TRANSMIȚĂTOARELOR
AR	إلغاء أجهزة الإرسال

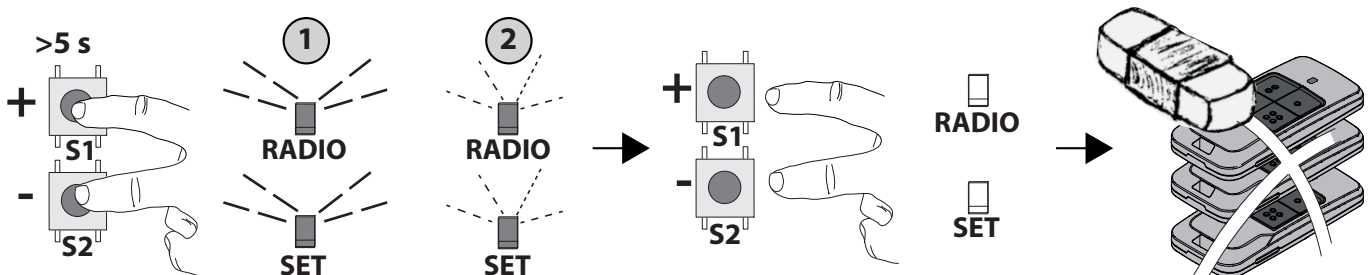

12

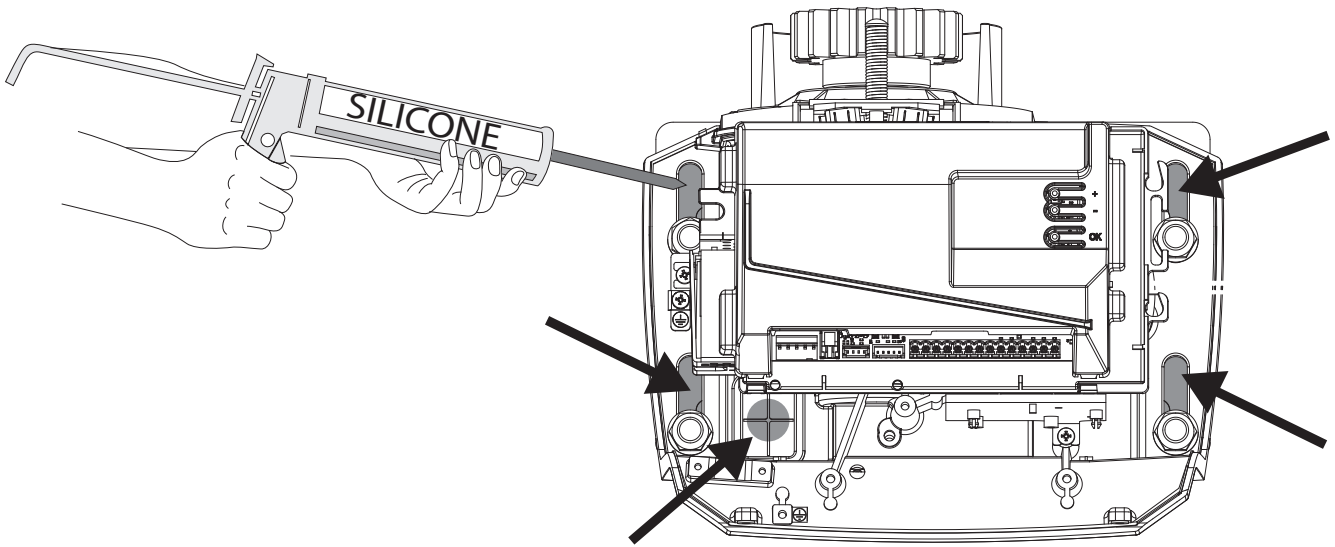

13

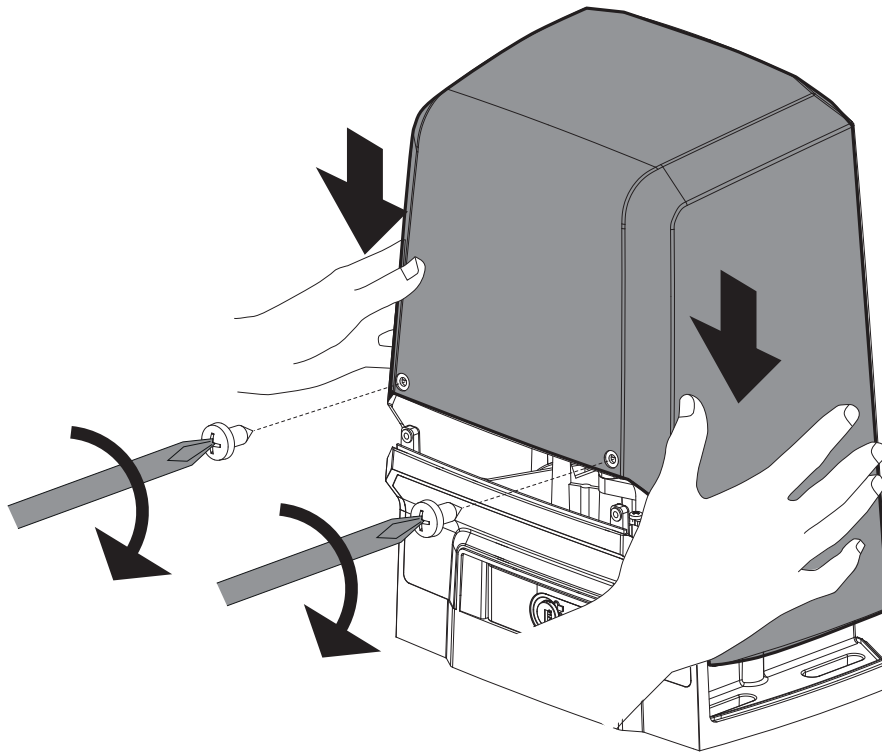

END



IT	MANOVRA MANUALE
EN	MANUAL OPENING
FR	OUVERTURE MANUELLE
ES	APERTURA MANUAL
DE	MANUELLE ÖFFNUNG
NL	HANDMATIGE OPENING
PT	ABERTURA MANUAL



EL	ΧΕΙΡΟΚΙΝΗΤΟ ΑΝΟΙΓΜΑ
PL	OTWIERANIE RĘCZNE
RU	РУЧНОЕ ОТКРЫТИЕ
CS	MANUÁLNÍ OTEVÍRÁNÍ
TR	MANUEL AÇMA
HR	RUČNO OTVARANJE
RO	DESCHIDERE MANUALĂ
AR	فتح يدوي

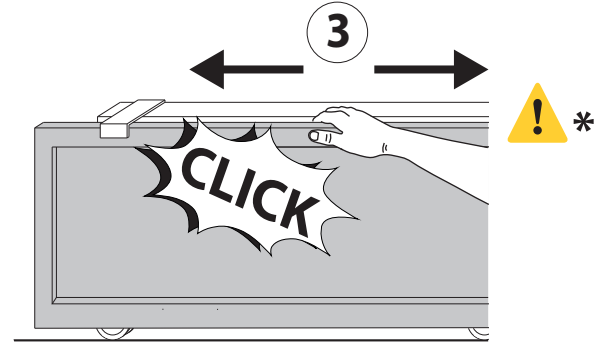
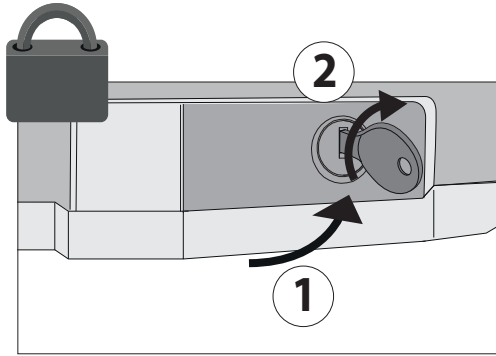
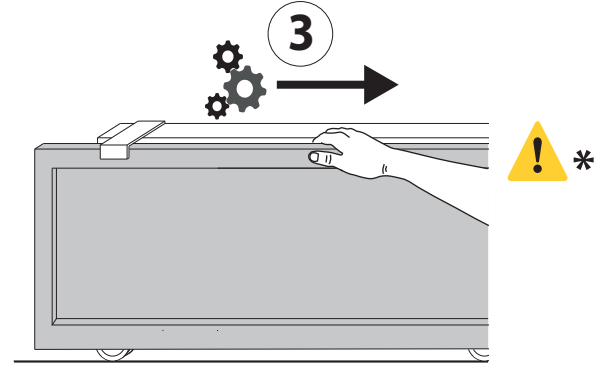
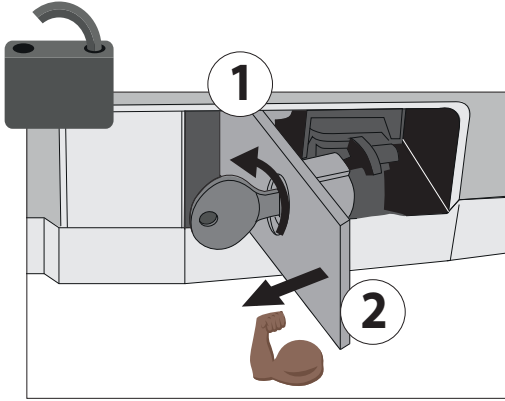

IT	Attenzione! Non spingere VIOLENTEMENTE l'anta del cancello.
EN	Warning! Do not push the gate WITH EXCESSIVE FORCE
FR	Attention! Ne poussez pas VIOLEMMENT le vantail du portail.
ES	¡Atención! No empuje CON VIOLENCIA la hoja de la puerta.
DE	Achtung! Schieben Sie den Torflügel nicht MIT GEWALT an.
NL	Let op! Duw niet MET GEWELD tegen de deur van het hek.
PT	Atenção! Não empurrar COM FORÇA a folha do portão.

EL	Προσοχή! Μην σπρώχνετε ΜΕ ΜΕΓΑΛΗ ΔΥΝΑΜΗ το φύλλο της πύλης.
PL	Uwaga! Nie należy GWAŁTOWNIE popychać skrzydła bramy.
RU	Внимание! Не толкайте СЛИШКОМ СИЛЬНО створку ворот.
CS	Pozor! Na křídlo brány netlačte PŘÍLIŠNOU SILOU.
TR	Dikkat! Kapının kanadını ŞİDDETLİ bir şekilde itmeyin.
HR	Nemojte gurati vrata uz primjenu PREKOMJERNE SILE!
RO	Nu împingeți bariera CU FORȚĂ EXCESIVĂ.
AR	لا تدفع البوابة بقوة زائدة



AZIENDA CON
SISTEMA DI GESTIONE
CERTIFICATO DA DNV GL
= ISO 9001 =
= ISO 14001 =

